



CARE HOME CATALOGUE

HEALTHCARE SOLUTIONS DESIGNED FOR LIFE

PRODUCT EXPERTISE

THERAPEUTIC SOLUTIONS

SERVICE EXPERTISE



2021/2022

WIN  CARE

WIN CARE

WinnCare manufactures and supplies ethical, transformative healthcare solutions and products designed to support user independence, while protecting care givers and our environment.



MOVING AND HANDLING

- The Importance of Moving
- Pallas Stand Aid
- Stellar Stand Aid
- Titan Mobile Hoist
- Winn'Motion 175
- Solar Mobile Lifter
- Luna Ceiling Hoist
- Spreader Bars
- Mobile Flex Gantry
- Slings

HYGIENE

- Triton Hygiene Chair
- Shower Trolley

TECHNICAL AID DEVICES

- Duo Bed Rails
- Epoxy Side Rails
- Full Length Wooden Side Rails
- Technical Aid Side Rails
- Headboards and Footboards

FURNITURE

- Carmen Bedroom
- Auzence Bedroom
- Dagone Bedroom
- Val de Vie Bedroom
- Cote de Lumiere Bedroom

LIFTING CUSHION

- Mangar Camel Lifting Cushion
- Mangar Elk Lifting Cushion
- Mangar Eagle Lifting Cushion
- Post Fall Management

PRESSURE CARE MATTRESSES

- Dynamic Mattresses
- Ekamove Patient Turning System

Our extensive product range is designed to meet the needs of businesses operating in the long-term care sector. Our portfolio embraces modern healthcare by giving flexible functionality, choice of colour and finish, together with enduring style, comfort and quality.

Our range includes;

- Safe patient handling products
- Beds and bedroom furniture
- Pressure Care mattresses and cushions
- Hygiene products

Contact us today

For more information visit

winncare.uk

Email: enquiries@winncare.uk

Phone: 0800 2800 485

PRODUCT EXPERTISE

THERAPEUTIC SOLUTIONS

SERVICE EXPERTISE



Our stylish, functional product range is the result of more than 40 years of research, design and industry collaboration. Ideal for care homes, nursing homes and assisted living facilities, the ergonomics of our portfolio have been carefully considered with user experience being our up-most priority.



Our solution-based approach to product development includes built-in functionality and flexibility that supports residents losing mobility, living with dementia or challenged with regular falls.

Combining the appropriate placement of equipment with efficient space planning will positively impact the quality of care you can offer your residents. Our team will work with care home managers, architects and designers to create a practical, safe environment.

Product solutions designed to enhance care home life



Ergonomically designed



Flexibility

EASY



Easy to use



Warranty



Hygienic



SAFE PATIENT LIFTING - THE IMPORTANCE OF MOVING

Encouraging residents to keep active for as long as possible is vital to wellbeing and long-term health prospects.

Selecting the right equipment and environment, combined with best practice in moving and handling procedures, empowers the resident to engage with the process and maintain levels of strength and mobility.

The following is a guide to use of lifting equipment, but an individual risk assessment for each resident is essential in order to tailor care appropriately.



Stand Aid

Stand Aids are ideal to move residents who can assist to some extent in a sit to stand transfer. Encouraging the resident to use this piece of equipment while they are still able will promote mobility and independence.

Mobile Hoists

Mobile hoists are ideal for moving residents with no mobility or strength to support their own weight. They are a flexible solution but should not be used to move people long distances. Always assess the environment for space before using.

Ceiling Hoists

As with mobile hoists, ceiling hoists are for moving people with no mobility or strength to support their own weight. They are generally less arduous for a carer to operate than a mobile hoist and are the more suitable for longer distance transfers.



Lifting cushions

Regular falls can cause a further fear of falling, resulting in a reduction of activity if not handled safely and in a dignified manner. The Mangar Camel, ELK and Eagle Lifting cushions are light, portable and perfect for frequent fallers.



 **MOVING AND HANDLING**



Product Code: 011-01528UK

Pallas Stand Aid 175

The Pallas 175 is a compact stand aid for individuals able to bear partial body weight when transitioning between seated and standing positions, such as from bed to wheelchair and wheelchair to toilet. Ideal for home use, and healthcare facilities. Extra lifting hooks on this model allows for seated transfers, increasing its versatility for multiple uses.

Key Features and Benefits

- Market-leading compact size
- Adjustable knee support of height, angle and depth to allow for tall or short patients
- Foot plate height extensions
- Ergonomic handles with several gripping positions
- Low friction wheels
- Electrical emergency lowering

TECHNICAL SPECIFICATIONS	
Lifting capacity (SWL)	175 kg
Lifting interval	728 / 1605 mm
Width external	base min/max 595 / 945 mm
Width internal	base min/max 463 / 815 mm
Chassis height front/back	120 / 150 mm
Length of legs	1001 mm
Lifting method	Electrical
Leg spreading method	Manual
Emergency lowering	Manual
Emergency stop	Electrical
Turning radius	1155
Wheel diameter front/back	ø75 / ø100
Total weight	47 kg
Weight heaviest single part	17.5 kg



Product Code: 011-01610EU

Stellar 170 Stand Aid

Stellar is the new state-of-the-art stand aid. With its elegant Scandinavian design with supreme functionality the Stellar has been developed to move users, who can assist to some extent in a sit to sit transfer.

Key Features and Benefits

- **The lifting and lowering pattern is more natural**, and the user is placed correctly in the chair
- **High-low lift range** from 800 mm to 1600 mm
- **Compact** with a small turning radius of 1060 mm
- **Narrow and stable chassis**, which fits through doors with a width of only 700 mm
- **Electrical leg adjustment** with a maximum width of 920 mm (can be used with both wide chairs and wheel chairs)
- **Easy clean** with smooth surfaces without contours. Easy to wipe over after use
- **Linak control box** and actuator

TECHNICAL SPECIFICATIONS	
Lifting capacity (SWL)	170 kg
Lifting method	Electrical
Leg spreading method	Electrical
Emergency lowering	Manual
Emergency stop	Manual
Total weight	51.6 kg
Battery capacity	60-80 lifts
Min. width	700 mm

MOVING AND HANDLING



Product code: L0900 -UK

Winn'Motion 175

Meets standard en ISO 10535: 2007 for the transfer for people with limited movement by hoist. Winn'Motion model 150 also available.

Key Features and Benefits

- Emergency stop button on the side of the control box.
- Audible signal when the battery is running low.
- Jack with anti-collapse system.
- Jack can be manually released using an ergonomic rotary knob.
- Feet can be manually moved further apart using a pedal system.
- **Light and compact** the Winn'Motion is adapted for use in Care homes and in the home.
- **Easy to transport and store away.**
- **The excellent lifting range allows patients to be lifted from the floor**
- **With a secured 4 point spreader bar** patients can be moved securely and with comfort.

TECHNICAL SPECIFICATIONS

Lifting capacity (SWL)	175 kg
Lifting method	Electrical
Leg spreading method	Manual
Emergency lowering	Manual
Emergency stop	Manual
Total weight	36 kg
Battery capacity	40 lifts
Min. width	650 mm



Product code: 010-01400

Solar 185

Solar's Scandinavian design with its sweeping elegant lines makes an attractive choice for use at home or in a healthcare environment. Its excellent lifting range allows clients to be lifted from the floor.

Key Features and Benefits

- **Solar's Scandinavian design** with its sweeping elegant lines makes it an attractive choice for home care or institutional use
- **Advanced control system** with emergency stop. The LCD screen shows the condition of the battery, service overview and lifting mode
- **Lift patients from the floor** with an excellent lifting range of 440mm to 1780mm
- **The mobile lift is easy to manoeuvre** thanks to the new ergonomic hand grip design and smooth rolling wheels
- **The system records and shows the number of lifts** performed and also the date of the next service
- **For patients up to 175 kg**
- **3-point spreader bar available**

TECHNICAL SPECIFICATIONS

Lifting capacity (SWL)	185 kg
Lifting method	Electrical
Leg spreading method	Electrical
Emergency lowering	Manual
Emergency stop	Manual
Total weight	50 kg
Battery capacity	40-60 lifts
Min. width	680 mm
Weight heaviest single part	24 kg



Luna Ceiling Hoist IPx4

The innovative Luna Ceiling Hoist combines Scandinavian design with excellent functionality, providing a mix of fixed and portable lifting solutions within one device.

Key Features and Benefits

- **Can be used as a fixed or portable hoist** which is a cost effective solution covering a mix of lifting requirements
- **Quick release mechanism** to detach the lift from the track in a matter of seconds –no tools required
- **Hand control** charged through wall mounted docking station and has a secure and reliable mechanism for hooking the hand control to the Luna lift.
- **Patented Ergolet spreader bar and sling hook system** ensuring safe and simple sling attachment. Minimum downward pressure locks the sling hook. Pull upwards to unlock sling hook.
- **Charging indicators** on the hand control including low battery visual LED
- IPx4 means it is safe to use in wet environments allowing for safe transfers in bathrooms
- IPx7 hand control tolerates immersion in water
- Electrical and manual emergency stop with emergency lowering function on both the hand control and Luna unit itself

TECHNICAL SPECIFICATIONS

Lifting capacity (SWL)	200/275 kg
Length of lifting strap	2200 mm
Weight	6.7 kg w/o spreader bar
Measurements	320 x 130 mm
Battery operation	36 V, lead acid batteries
Charging	100 - 240 V, 0,5A.
Chassis Aluminium	Housing High impact, moulded ABS
Noise Lwa during lifting	Lowering without load is 49dB(A)
Lifting speed down	44 mm/sec with 89 kg load/sec with 196 lbs load
Lifting speed up	30 mm/sec with 89 kg load
No. of lifts per charge	50 lifts of 0.5 m with 100 kg

Version	Item No.
LunalPx4/200 kg, portable (strap) – white/grey	015-03020/015-03021
LunalPx4/275 kg, portable (strap) – white/grey	015-03022/015-03023
LunalPx4/200 kg, fixed (bayonet) – white/grey	015-03026/015-03027
LunalPx4/275 kg, fixed (bayonet) – white/grey	015-03028/015-03039
LunalPx4/200 kg, fixed (bayonet), 2 ports – white/grey	015-03032/015-03031
LunalPx4/275 kg, fixed (bayonet), 2 ports – white/grey	015-03034/ 015-03033
LunalPx4/200 kg, room to room – white/ grey	015-03035/ 015-03036
LunalPx4/275 kg, room to room – white/grey	015-03037/ 015-03038

Accessories	Item no.
Hand control IPx4 with cable on top*	015-03105
Hand control IPx4 with cable on bottom*	015-03101
Hand control IPx7	015-03109

Features

- Soft start and stop motor control
- Electrical emergency lowering
- Electrical emergency stop
- Ceiling tracks and Gantry's available
- Low battery indicator (visual LED)
- Charging indicators
- Power on indicators
- Multiple accessories, including scales, easy mover, etc.
- Overload protection
- Emergency brake system
- Can be fixed to existing tracking
- Children cartoon casing also available





Key standard functions

- Extensive range for specific and general use
- Patented sling hooks on all spreader bars
- Easily interchangeable to allow for multiple use
- Can be used on both mobile lifters and ceiling hoists

SPREADER BARS

There is a complete range of spreader bars in various sizes and models to suit all care needs and transfer situations. All spreader bars are equipped with our patented sling hook system.

The two point spreader bar is suitable for a standard transfer. It is available in 3 widths.

There is also the unique V shaped 3-point spreader bar. This increases the distance between the shoulder strap section and the leg strap section, opening up the sling for a more comfortable lift.

In other situations it will be more suitable to use one of our 4-point spreader bar solutions. We have 2 different types.

The largest one being the H-solution with 4 points equally placed from the center for optimal weight distribution. There is a more flexible option also where you use a standard 2 point

spreader bar and then add 2 extra side spreader bars onto the end 2 points.

Then there is a flexible 4 point spreader bar which fits as standard for the width of shoulders and hips.

By using 3-point or one of the 4-point spreader bars, you will have a more open and flexible transfer, which take the clients special needs into consideration.



Mobile Flex

Suitable for people who need an immediate and/or temporary lifting solution that can be easily and simply fitted, used and removed. The Mobile Flex is easy to assemble. No tools are required to adjust the height and width to provide reliable temporary solutions.

Adjusting the height via gas spring is carried out in just a few seconds providing immediate use for the carer and client. The telescopic tracks give enough lifting height to provide solutions that are suitable for most rooms and most transfer situations.

The Mobile Flex is when combined with the innovative Luna ceiling lift, is a simple and functional lifting system and the ideal choice for either home care or institutional use.

The Mobile Flex provides a lifting capacity up to 275 kg thus utilizing the full range of the Luna ceiling lift.

Mix and match

Maybe you just need a 2-post system over a bed, or maybe you need full room covering with a 4-post system.

No matter what your needs are, Mobile Flex is your flexible solution, which modular parts can be fitted and combined for your purpose.



2-post system

Height & width adjustable

Only takes 30 minutes to assemble



4-post system

Fully adjustable, room covering and free-standing

Only takes 1 hour to assemble

SLINGS

Practical and comfortable our slings have excellent seating comfort and ensure correct user positioning.

Each sling is colour coded to identify size. Please see our user guide on the opposite page for detailed information.

All of the slings are easily compatible with the Ergolet hook system which are on the spreader bars we also have available.

There are 3 different materials on the slings

- Polyester – Extra durable and easy to clean
- Polyester Net – Suitable especially for bathing
- Nonwoven – For disposable slings





Disposable Comfort Sling



**Universal Amputee Sling
with extra leg straps**



Universal Basic Sling

PRODUCT	PRODUCT CODE	STRAP COLOUR	SIZE	Y	X	Z	SWL	USABILITY
Universal Basic sling - polyester	009-09803	grey	XS	37	50	-	275 kg	<ul style="list-style-type: none"> • For users with lack of stability of torso. • For transfers from a sitting or lying position. • For transfers in mobile and stationary hoists.
	009-09804	red	S	42	55	-	275 kg	
	009-09805	yellow	M	48	66	-	275 kg	
	009-09806	green	L	52	75	-	275 kg	
	009-09807	blue	XL	68	75	-	400 kg	
	009-09808	black	XXL	78	75	-	400 kg	
Universal Basic sling - polyester mesh	009-09813	grey	XS	37	37	-	275 kg	
	009-09814	red	S	42	42	-	275 kg	
	009-09815	yellow	M	48	48	-	275 kg	
	009-09816	green	L	52	52	-	275 kg	
	009-09817	blue	XL	68	68	-	400 kg	
	009-09818	black	XXL	78	78	-	400 kg	
Universal Basic sling, with head support - polyester	009-09823	grey	XS	37		75	275 kg	<ul style="list-style-type: none"> • For users with lack of stability of torso. • For transfers from a sitting or lying position. • For transfers in mobile and stationary hoists.
	009-09824	red	S	42		80	275 kg	
	009-09825	yellow	M	48		91	275 kg	
	009-09826	green	L	52		100	275 kg	
	009-09827	blue	XL	68		100	400 kg	
	009-09828	black	XXL	78		100	400 kg	
Universal Basic sling, with head support - polyester mesh	009-09833	grey	XS	37		75	275 kg	
	009-09834	red	S	42		80	275 kg	
	009-09835	yellow	M	48		91	275 kg	
	009-09836	green	L	52		100	275 kg	
	009-09837	blue	XL	68		100	400 kg	
	009-09838	black	XXL	78		100	400 kg	
Universal Hammock sling - mesh	009-09673	grey	XS	37	50		275 kg	<ul style="list-style-type: none"> • For less active users, who are in seated position for longer periods. • For transfers from a lying position. • For transfers in mobile and stationary hoists.
	009-09674	red	S	42	55		275 kg	
	009-09675	yellow	M	48	66		275 kg	
	009-09676	green	L	52	75		275 kg	
	009-09677	blue	XL	68	75		400 kg	
	009-09678	black	XXL	78	75		400 kg	
Universal Hammock sling, with head support - mesh	009-09683	grey	XS	37		75	275 kg	
	009-09684	red	S	42		80	275 kg	
	009-09685	yellow	M	48		91	275 kg	
	009-09686	green	L	52		100	275 kg	
	009-09687	blue	XL	68		100	400 kg	
	009-09688	black	XXL	78		100	400 kg	

PRODUCT	PRODUCT CODE	STRAP COLOUR	SIZE	Y	X	Z	SWL	USABILITY
Universal Amputee sling, with extra leg straps- polyester	009-09743	grey	XS	37	50	-	275 kg	<ul style="list-style-type: none"> • For users who have a single or double amputation. • For transfers from a sitting or lying position. • For transfers in mobile and stationary hoists.
	009-09744	red	S	42	55	-	275 kg	
	009-09745	yellow	M	48	66	-	275 kg	
	009-09746	green	L	52	75	-	275 kg	
	009-09747	blue	XL	68	75	-	400 kg	
	009-09748	black	XXL	78	75	-	400 kg	
Universal Comfort sling with head support - polyester	009-09763	grey	XS	37	-	75	275 kg	<ul style="list-style-type: none"> • For users with increased disability or other special needs. • For transfers from a sitting or lying position. • For transfers in mobile and stationary hoists.
	009-09764	red	S	42	-	80	275 kg	
	009-09765	yellow	M	48	-	91	275 kg	
	009-09766	green	L	52	-	100	275 kg	
	009-09767	blue	XL	68	-	100	400 kg	
	009-09768	black	XXL	78	-	100	400 kg	
Universal Comfort sling with head support - polyester mesh	009-09773	grey	XS	37	-	75	275 kg	
	009-09774	red	S	42	-	80	275 kg	
	009-09775	yellow	M	48	-	91	275 kg	
	009-09776	green	L	52	-	100	275 kg	
	009-09777	blue	XL	68	-	100	400 kg	
	009-09778	black	XXL	78	-	100	400 kg	
Disposable Comfort Sling without head support (10 pcs.)	008-04104	red	S	42	55	-	275 kg	<ul style="list-style-type: none"> • A disposable sling is perfect for situations where a high hygienic standard is needed, e.g. if there is a risk of infection. • For users with increased disability or other special needs. • For transfers from a sitting or lying position. • For transfers in mobile and stationary hoists.
	008-04105	yellow	M	48	66	-	275 kg	
	008-04106	green	L	52	75	-	275 kg	
Disposable Comfort Sling with head support (10 pcs.)	008-04114	red	S	42	55	-	275 kg	
	008-04115	yellow	M	48	66	-	275 kg	
	008-04116	green	L	52	75	-	275 kg	
Toilet sling without head support - polyester	009-09543	grey	XS	37	50	-	275 kg	<ul style="list-style-type: none"> • For transfers to and from the toilet. • For users with a good control of the head and torso. • For transfers from a sitting or semi-sitting position. • Used for transfers in mobile and stationary hoists.
	009-09544	red	S	42	55	-	275 kg	
	009-09545	yellow	M	48	66	-	275 kg	
	009-09546	green	L	52	75	-	275 kg	
	009-09547	blue	XL	68	75	-	400 kg	
	009-09548	black	XXL	78	75	-	400 kg	

PRODUCT	PRODUCT CODE	STRAP COLOUR	SIZE	Y	X	Z	CHEST	SWL	USABILITY
Low Back sling - polyester	009-09633	grey	XS	37	50	-	-	275 kg	<ul style="list-style-type: none"> • For users with a good upper body & head control. • Used for transfers from a sitting or semi-sitting position. • Used for transfers in mobile and stationary hoists.
	009-09634	red	S	42	55	-	-	275 kg	
	009-09635	yellow	M	48	66	-	-	275 kg	
	009-09636	green	L	52	75	-	-	275 kg	
	009-09637	blue	XL	68	75	-	-	400 kg	
	009-09638	black	XXL	78	75	-	-	400 kg	
Walking sling	009-09572	grey	XS	-	-	-	62-75	180 kg	<ul style="list-style-type: none"> • For users with good upper body control and some lower limb function. • Used for transfers from a sitting position. • Used for transfers in stand aids.
	009-09883	red	S	-	-	-	76-84	180 kg	
	009-09884	yellow	M	-	-	-	55-92	180 kg	
	009-09885	green	L	-	-	-	93-105	180 kg	
	009-09886	blue	XL	-	-	-	106-114	180 kg	
	009-09887	black	XXL	-	-	-	116-130	180 kg	
Standing sling	009-09594	red	S	-	-	-	76-84	275 kg	<ul style="list-style-type: none"> • Supports during standing movement and can also be used for gait training, for users with sufficient stability and standing function, but low balance. • Supports central part of back. Has anti-slip material on the back. • Sitting to and from e.g. bed, wheelchair/bathing and shower chair.
	009-09595	yellow	M	-	-	-	55-92	275 kg	
	009-09596	green	L	-	-	-	93-105	275 kg	
	009-09597	blue	XL	-	-	-	106-114	275 kg	
	009-09598	black	XXL	-	-	-	116-130	275 kg	

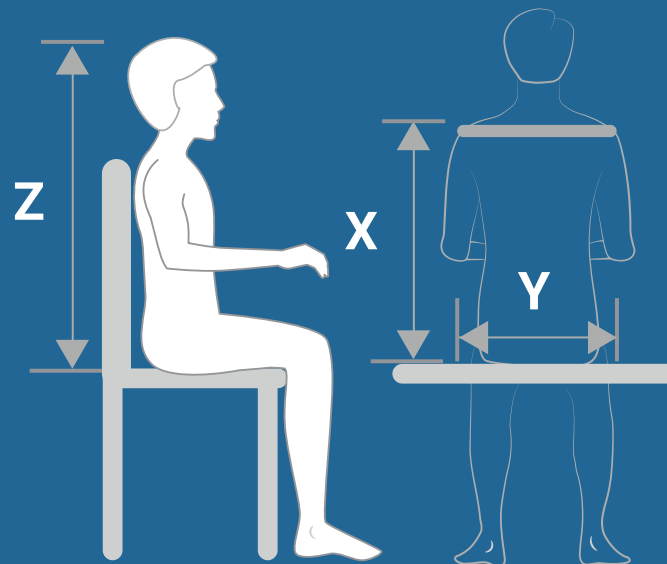

Y = Hip Measurement

X = Measurement from neck to lower back

Z = Measurement from head to lower back





MANGAR Camel Lifting Cushion

The Camel Lifting Cushion will both sit up and lift a fallen person.

EASY TO FIT

- Lifting cushion is inflated using an Airflo Compressor with a simple hand control
- Simple to use, requiring very little training
- Suitable for indoor and outdoor use
- Can be used independently or assisted

SIMPLE TO MAINTAIN

- Clean using a proprietary non-abrasive mild liquid cleaner.
- Easy to deflate, fold away and store in the carry bag provided
- Does not need a LOLER certificate
- The material is designed to exceptionally high standards with extraordinary durability, strength & performance in the toughest of environments

SAFE TO USE

- Lifts the frailest person up to 320 kg from the floor
- Stable and supportive
- Ideal for carers of individuals with neurological disorders who fall regularly

IMPROVES WELL-BEING

- Provides a safe, dignified lift for a fallen person
- Reduces the risk of musculoskeletal injury for the carer
- Individuals with a cognitive impairment are less distressed when lifted with a Camel
- The backrest gives additional support and is particularly suitable for bariatric patients

TECHNICAL SPECIFICATIONS

Max user weight	320 kg
Max height	56 cm
Min height	Flat
Seat depth	47 cm
Total length	112 cm
Width	70 cm
Total product weight	6.5 kg
Back/headrest length	81 cm
Airflo Compressor	24
Lifting performance per charge	Up to 4 lifts

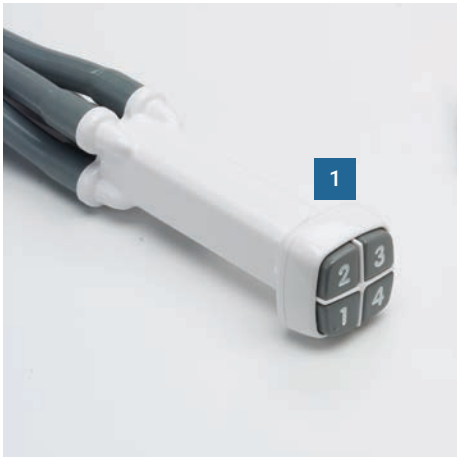

Features

1. **Easy to setup** - connect the four hoses from the hand control to the corresponding numbers and coloured connectors on the Camel.
2. **The head should lie on the Camel badge** and the body should lie centrally.
3. **The backrest** may be partially inflated before the lower sections.
4. **Made from very strong polyurethane coated nylon material.**
5. **Each layer inflates individually** ideal for single-handed care.

Accessories

- Slide sheet
- Camel Carry Bag



Product code: MPCA060400



Scan me



MANGAR ELK Lifting Cushion

The ELK is a lifting cushion designed to lift from the floor.

EASY TO FIT

- Lifting cushion is inflated using an Airflo Compressor with a simple hand control
- Simple to use, requiring very little training
- Suitable for use inside or out
- Can be used by one carer

SIMPLE TO MAINTAIN

- Clean using a proprietary non-abrasive mild liquid cleaner.
- Easy to deflate, fold away and store
- The material is designed to exceptionally high standards with extraordinary durability, strength & performance in the toughest of environments

SAFE TO USE

- Lifts the frailest person up to 450 kg from the floor
- Exceptionally rigid and stable
- Ideal for carers of individuals with neurological disorders who fall regularly

IMPROVES WELL-BEING

- Provides a safe, dignified lift for a fallen person
- Reduces the risk of musculoskeletal injury for the carer
- Can be used in confined spaces where traditional lifting equipment may not fit

TECHNICAL SPECIFICATIONS

Max user weight	450 kg
Max height	56 cm
Min height	Flat
Seat depth	50 cm
Width	57"
Total product weight	3.6 kg
Airflo Compressor	24
Lifting performance per charge	Up to 9 lifts



Features

1. **4-Way Hand Control.**
2. **Made from very strong polyurethane coated nylon material.**
3. **Remove or keep stability bar** to provide extra comfort for the user.
4. **Can be used to lift a stretcher.**
5. **Easy to setup** - connect the four hoses from the hand control to the corresponding numbers and coloured connectors on the ELK.
6. **Powered by an Airflo 24 Compressor.**

Accessories

- ELK Stretcher Bars
- Slide sheet
- ELK End Cap Set



Product code: MPCA070400





MANGAR Eagle Lifting Cushion

The Eagle lifting cushion will both sit up and lift a fallen person. It has a small footprint and can be used in small spaces such as a bathroom.

EASY TO FIT

- Lifting cushion is inflated using an Airflo Compressor with a simple hand control
- Simple to use, requiring very little training
- Suitable for indoor and outdoor use
- Can be used independently or assisted

SIMPLE TO MAINTAIN

- Clean using a proprietary non-abrasive mild liquid cleaner
- Easy to deflate, fold away and store in the carry bag provided
- Does not need a LOLER certificate
- The material is designed to exceptionally high standards with extraordinary durability, strength & performance in the toughest of environments

SAFE TO USE

- Lifts the frailest person up to 35 stone/ 220 kg from the floor
- Exceptionally rigid and supportive to back
- Ideal for use in supported living apartments and home care

IMPROVES WELL-BEING

- Provides a safe, dignified lift for a fallen person
- Reduces the risk of musculoskeletal injury for the carer
- The backrest gives additional support to raise the person from lying to sitting
- Small footprint is ideal for use in a home environment

TECHNICAL SPECIFICATIONS

Max user weight	220 kg
Max seat height	56 cm
Min height	Flat
Seat depth	57 cm
Total length	112 cm
Width	64 cm
Total product weight	4.5 kg
Back/headrest length	52 cm
Airflo Compressor	24
Lifting performance per charge	Up to 6 lifts



Features

1. **Easy to setup** - connect the four hoses from the hand control to the corresponding numbers and coloured connectors on the Eagle.
2. **The backrest** provides support to the back and head.
3. **Made from very strong polyurethane coated nylon material.**
4. **Each layer inflates individually** ideal for single-handed care
5. **Sides of the Eagle can be folded up** to allow manoeuvring into tight spaces.

Accessories

- Slide sheet
- Eagle Carry Bag



Product code: HKA0100



POST FALL MANAGEMENT

While 50% of adults aged over 80 will fall at least once a year (NICE), in care homes this is three times more likely to happen (Helped the Aged). In 45% of cases, the person who has fallen is uninjured (Wales Ambulance Service Trust) but the ambulance service is routinely called to assist with a lift.

Uninjured fallen residents are routinely categorised as a low priority with Ambulance Trusts and this can lead to long wait times for paramedic help to arrive.

There is a direct correlation between recovery and how long people lie on the floor after a fall.

Lying on the floor for a long time following a fall is one of the most serious consequences. Even a delayed initial recovery greater than 10 minutes will begin to impact a fallen resident and a 'Long-Lie' of more than an hour is associated with;

- Skin damage resulting in pressure sores
- Dehydration
- Reduced confidence
- Pneumonia
- Increased anxiety
- Kidney failure (through rhabdomyolysis)
- Hypothermia
- Death

To perform a health assessment on a fallen resident many ambulance services use an algorithm called ISTUMBLE, which care homes across the UK are adopting in the aim to align to best practice in post fall management. The health assessment used with the appropriate piece of lifting equipment safeguards the lives of residents and avoids unnecessary hospital admissions.



You can use the algorithm as pictured on the right or through the ISTUMBLE app, this is recognised and used by paramedics across the UK to inform decisions around lifting. It simply uses a series of questions to work you through the algorithm and let you know the best course of action to take. Available through Google Play and the App Store.

When should you call an ambulance?

The Ambulance Service in the UK issue guidelines on when to call the emergency services. This one, called ISTUMBLE, is used by West Midlands Ambulance Service NHS Trust.

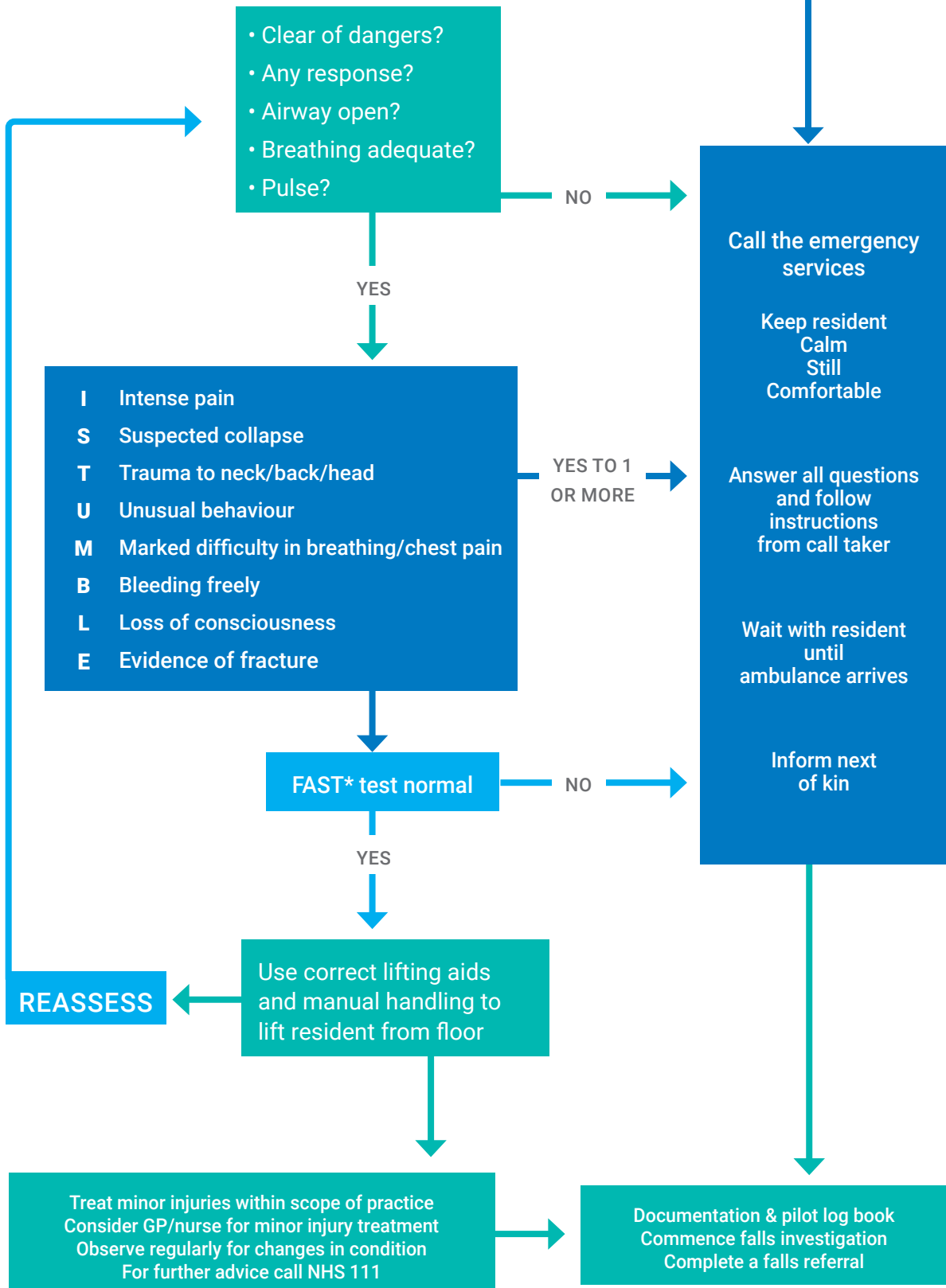



Product code: 044-00050

Triton Hygiene Chair

The Triton Hygiene Chair is a new and improved powered, height adjustable, tilt-in-space shower commode chair.

BETTER WORKING ENVIRONMENT

- Correct working posture eliminates strain and stress on the caregiver's back, shoulders and knees.
- The height adjustment allows an optimal positioning of the chair, ensuring a correct working posture for the care giver.

INCREASED COMFORT

- With the electrical seat tilt and adjustable backrest, the Triton Dual makes it easy for the user to find the most comfortable sitting position.
- The lift height of 40 cm helps both the caregiver and the user.

EASY TO CLEAN

- Developed from the Easy-Clean principle, which means there are no small corners or edges. The chair has closed screws/joinings and fully welded steel, which prevents water from entering the pipes. It is also treated with double coating which makes it rust resistant.
- IPx6W rated: Can be cleaned in washing machines up to 250 times due to LINAK IPX6 Washable DURA™ (50 washes is standard).

IMPROVES INDEPENDENCE

- For the user, the height adjustment means increased independence; it is possible to adjust the chair, so the user can reach the sink and look in the mirror - therefore the user can help take care of his own personal hygiene.

TECHNICAL SPECIFICATIONS

Max user weight	150 kg
Distance btw. arm rest	468 mm
Seat depth	430 mm
Seat width	460 mm
Seat height	544-943 mm
Total width	572 mm
Length	996-1294 mm
Total height (w/o head rest)	886-1540 mm
Weight	41 kg
Tilt angle	+7 to -30°
IP class	IPx6W
Charging time	6 hours
Battery capacity	80-100 lifting cycles



HYGIENE



Product code: C4300

Shower Trolley

The Shower Trolley provides a comfortable experience for both the user and carer.

COMFORT

- Padded PVC polyester, caribbean green, 2 cm thick, secured on a water-repellent compact top.
- The variable height from 52 to 88 cm enables the caregiver to work in an ideal position, avoiding the risk of lumbar pain.
- Foam padding

SAFETY

- ABS base protector
- Centralised braking option with 4 x 125 mm castors, incl. 1 directional
- Ground clearance 13 cm, or 15 cm with centralised braking
- For patients up to 155 kg
- The 20 cm high protective side rails guarantee complete safety for patients

CONVENIENT

- Slightly sloping base board for good water evacuation
- Hydraulic variable height that can be operated by a side pedal on both sides
- Head and foot push bars
- Thermoformed clothes basket, at the head of the trolley
- Retractable epoxy profiled side rails
- Pluggable drain outlet. Outlet pipe can be attached to be the side of the base board
- 185 cm outlet pipe, 0.4 cm
- 71.5 cm wide legs for improved stability

TECHNICAL SPECIFICATIONS

Dimensions	74 x 198 cm
Base board	1.78 m x 60 cm
Side rails	1.40 m x 20 cm
Weight	85 kg
Normal load in use	170 kg Patient 155 kg Accessories 15 kg



TECHNICAL SPECIFICATIONS

	Dimensions	Adjustable Height	Back Rest	Leg Rest	Lifting Capacity	Castors	Standards	Motorisation
AERYS 3 electrical functions without knee break without rtr position 3 electrical functions with knee break rtr/tr position	90 x 200 cm Bed base non-divisible with welded metal slats	24.5 cm to 80 cm	70°	Thigh section 26° and 16° feet adjustment by manual crank	SWL (1) 200 kg Patient weight up to 165 kg Accessories 15 kg Mattress 20 kg (Environment 3, 4 with no rtr/tr function and 5)	Head trolley with fixed metal castors Ø 100 mm Foot trolley with multi-directional castors and individual braking Ø 75 mm	IEC 60601 IEC 60601-2-52 compatible with environments 3	LINAK IP54

Handset, electric and mechanical parts: 5-year warranty*

Boards and accessories: 1-year warranty*

* Under normal conditions of use and excluding wearing parts
- please see instructions of use

(1) Safe Working Load



CARE
BEDS

AERYS Bed

The AERYS Bed has been designed to fit effortlessly into a home or care environment but with the functionality of a medical bed.

- Adjustable height mechanism, which can be customised to suit the individual patient
- Flexible height range makes it ergonomically beneficial for care givers
- One touch button to move bed into a chair position
- A stop in the -5 Trendelenburg position to reposition the patient
- A Trendelenburg position at -12 for emergencies
- A full range of foot and headboard colour and design choices gives ultimate flexibility for a aesthetic finishes

Key Features

- Height range 24.5 – 80 cm
- Size 90 x 200 cm
- SWL 200 kg
- Centralised braking on foot
- CPR electric back rest
- Compatible with the S.A.M Mobility Aid System
- Simple and easy to use controls



Product code: AE3P3F06



TECHNICAL SPECIFICATIONS

Description	Dimensions	Adjustable Height	Back Rest	Leg Rest	Lifting Capacity	Standards	Motorisation
ALDRYS' EVOLUTION II 3 electrical functions	90 x 200 cm divisible bed base	22 cm to 78 cm individual braking or 24 cm to 80 cm central braking	70°	Knee break 26° (thighs) and 16° feet adjustment by manual cranks	SWL (1) 170 kg Mattress 20 kg Patient 135 kg Accessories 15 kg	IEC 60601- 2-52 compatible with environments 3, 4 and 5	LINAK IP 66

- 2 accessory holders (lengthwise)
- 2 IV stand holders (at the head of the bed)

- 2 lifting pole holders (at the head of the bed)

(1) Safe Working Load

Handset, electric and mechanical parts: 5 year warranty

Boards and accessories: 1 year warranty*

* Under normal conditions of use and excluding wearing parts -
please see instructions of use



CARE
BEDS

ALDRYS Bed

The ALDRYS Bed has a range of features and functions making it ideal for use in care facilities or in the home.

- In-built safety features ensure a safe environment for vulnerable and elderly patients
- The bed is made from good quality, robust materials and comes with a five-year warranty
- Powered using LINAK actuators, there are several back and leg rest options available
- The bed has been optimised for maximum underbed clearance, meaning mobile hoists easily fit underneath
- Bed lowers to a 22 cm floor clearance, reducing the impact of any falls
- A full range of foot and headboard colour and design choices gives ultimate flexibility for aesthetic finishes
- Flexible height range makes it ergonomically beneficial for care givers
- Coloured, traditional and padded Eleganti boards give patients a visual cue and provide extra protection in the event of a bump

Key Features

- Height range 22 to 78 cm
- Size 90 x 200 cm
- Compatible with the S.A.M Mobility Aid System
- Simple and easy to use controls
- Choice of colours and designs
- Several back and leg rest options

STEP 1: Choose the bed base according to the variable height



STEP 2: Choose the bed configuration



Electric leg rest with thigh section.



Product code: AL5P3D1F06



Dimensions	Adjustable Height	Back Rest	Leg Rest	Lifting Capacity	Castors	Standards
140 x 200 cm	34 cm to 74 cm	70°	12° manual crank	SWL (1) 315 kg Mattress 30 kg Patient 270 kg Accessories 15 kg	Ø 100 mm with brake without thread guard	IEC 60601-2-52
160 x 200 cm			26° thigh sections (thighs) and 16° feet adjustment 160 x 200 cm by manual cranks			
140 x 200 cm						
160 x 200 cm by manual cranks						

- 2 accessory holders (lengthwise)
- 2 IV stand holders (at the head of the bed)
- 2 lifting pole holders (at the head of the bed)

Handset, electric and mechanical parts: 5 year warranty
 Boards and accessories: 1-year warranty*
 * Under normal conditions of use and excluding wearing parts
 - please see instructions of use

(1) Safe Working Load



CARE
BEDS

Duo Bed

The Duo Bed is designed for couples who would like to stay in the same bed, but where one or both of them have limited mobility. They can rest, read or sleep comfortably without disturbing the other person.

- Sleeps couples with a combined weight of 270 kg comfortably
- Two separate bed bases enable individual independence
- Each side of the bed can be individually moved into reclining, half-seated or flat position
- Easy to clean bed with welded metal slats
- Suitable for use at home or in care facility. The bed comes in a choice of two colours and designs
- Flexible height range makes it ergonomically beneficial for care givers

Key Features

- Size: 140 (2x70) cm or 160 (2x80) x 200 cm
- Height range from 34 to 74 cm
- Combined width of 140 cm (2x70) or 160 cm (2x80)
- Bed on fixed feet
- MEDIDOM II* Light Dragon Tree colour trim, with long side panels and skirting
- 2 models available with 2 and 3 electrical functions
- Compatible with S.A.M Mobility Aid System
- Simple and easy to use controls

Bed for couples up to 270 kg

2 sleeping widths:
140 (2x70) and 160 (2x80) cm

2 versions: 2 and 3 functions
with thigh section



14 cm optimized clearance
under the bed on feet or castors

Divisible bed base
with welded metal slats

3 Basic Finishes

- On castors, on castors with skirting or on fixed feet with skirting
- Wooden slatted bed base
- Two infrared remote controls



Product code: D08C8



ALUMINIUM AND WOODEN 1/2 SIDE RAILS

They are sliding side rails composed of 2 segments of identical dimensions. They are equipped with a patented locking/unlocking system guaranteeing the safety of its users. The metal part is aluminium, the upper part(handrail) is solid wood.

These side rails are removable and compatible with

- All our beds
- The boards in our range
- Our bedding

They comply with the EN 60 601-2-52 requirements on spacing.

They are available in 2 finishes for the handrail:

- Paint varnished according to the colours of the colour chart
- Glass paint according to the colours of the colour chart.

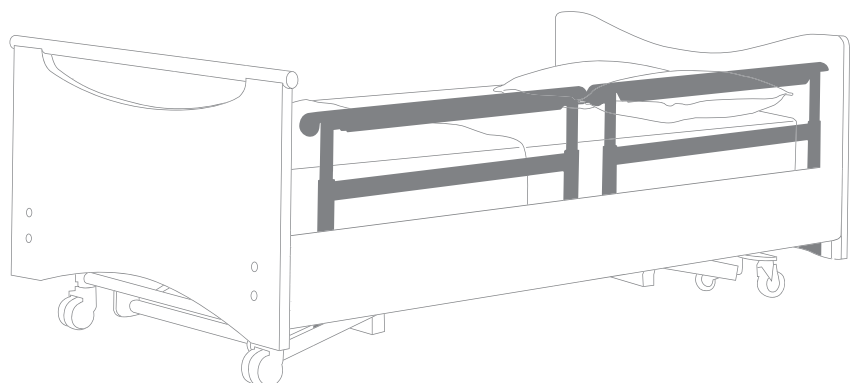



3/4 EPOXY SIDE RAILS

These retractable side rails are compatible with all our beds. The rails are equipped with a fixation system in order to prevent bad installations and comply with the EN 60 601-2-52 requirements on spacing. They are compatible with our bedding (photos opposite) and available in 4 colours according to the colour of the bed frame.

EPOXY PAINTS AVAILABLE



RAL 7035

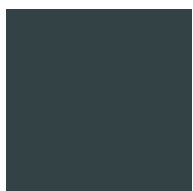

RAL 7035

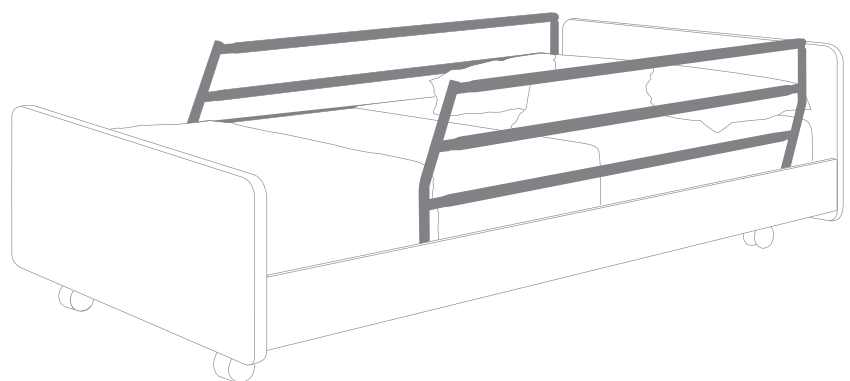



FULL LENGTH WOODEN SIDE RAILS

These are sliding side rails fixed in the headboards and footboards. They can be positioned on our entire bed line (width of 90/100/120/140/160cm).

These side rails are compatible with 3 boards of our range

CARMEN II



VAL DE VIE



COTE DE LUMIERE



They are available in 3 finishes:

- Light beech polymer coating
- Paint varnished according to the colours of the colour chart
- Gloss paint according to the colours of the colour chart.

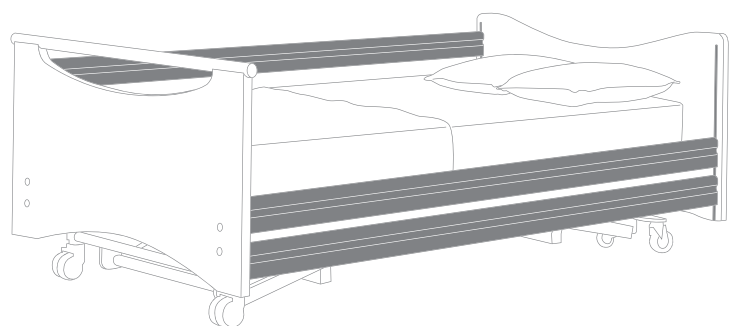



TECHNICAL AIDS SIDE RAILS

These are bed accessories providing new features to improve patients' mobility while facilitating the work of caregivers.

This range has been developed in collaboration with experts (occupational therapists and designers). Systems Aiding Mobility are patented accessories.

The SAM range is compatible with all our beds.

They comply with the 60 601-2-52 requirements on spacing.

PRINCIPLE:
 The SAM range improved the motor pattern of the patient during his/her "lying-seated" movement and contributes take part in daily life activities by mobilising these functional abilities. It improves caregiver safety postures and creates a free space for caregivers.

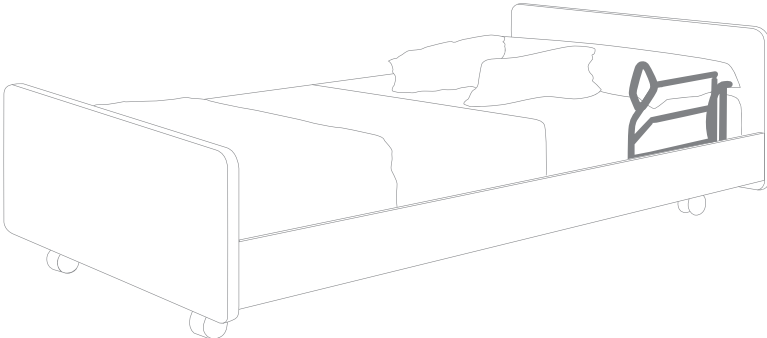

EVOLUTION



ACTIV



ERGONOMOM





Our beds and their accessories are designed and manufactured in compliance with European Directive 93/42/EEC. We have performed standardised testing on them in their commercial configurations, including the bed boards and accessories that we manufacture, so as to ensure maximum safety and performance for you.

WINNEA

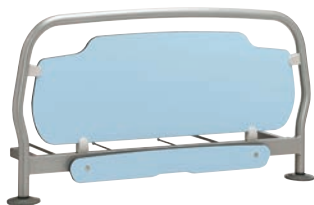

Headboard

- Crystal Blue finish
- Removable headboard

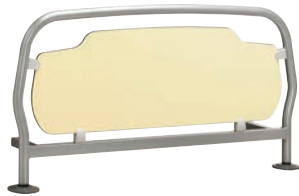

Footboard

- Sixties Yellow finish



Footboard

- Crystal Blue finish
- Optional blanket holder



WINNEA CIC

Handset, electric and mechanical parts: 5-year warranty*

Boards and accessories: 1-year warranty*

*Under normal conditions of use and excluding wearing parts - please see instructions of use

MADÉLIA



- Light Beech inside finish
- Ral1001 edging

ABELIA II *



- Light Beech inside finish
- Glued ABS edging. Dark Beech colour
- Ral1001 brown epoxy hand rail
- Ral1001 brown polyethylene ends

AUZENCE II



- Grey Dragon Tree inside finish
- RAL 7030 surround

VAL DE VIE *



- Light Beech inside finish
- Ral1001 surround

CARMEN II



- Headboard**
- Light Dragon Tree inside finish
 - Matching ABS edging



- Footboard**
- Light Dragon Tree inside finish
 - Matching ABS edging

DAGONE *



- Light Beech inside finish
- Ral1001 surround

ELEGANTI



- Dune and chocolate PVC
- Unique standard colours

COTE DU LUMIÈRE



- Light Beech inside finish
- Ral1001 surround

MEDIOM II



- Headboard**
- Light Dragon Tree inside finish
 - Matching edging



- Footboard**
- Light Dragon Tree inside finish
 - Matching edging

PRESSURE CARE MATTRESSES



Product code: VAXT6

Axtair Automorpho Axensor Range

The Axtair Automorpho mattress helps in preventing pressure ulcers in patients who are at high risk of pressure ulcer development or bedridden more than 15 hours a day. The mattress helps in treating existing pressure ulcers from stage 1 to 4.

The Range has a Patient Weight tolerance of 30 to 200 kg
Axensor AT12 & AT15

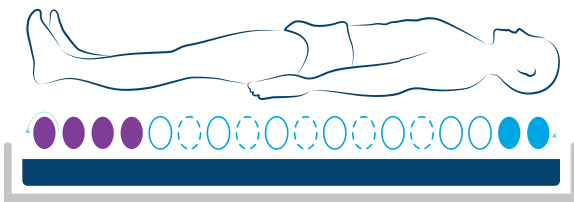

Key Features

OVERLAY MATTRESS 12 CM (AT12 MODEL)

- 12 cm therapeutic air cells
- Weight limit: 165 kg

MATTRESS 15 CM (AT15 AND AT15 DV MODELS)

- 15.5 cm therapeutic air cells
- Weight limit: 180 kg

3 THERAPEUTIC ZONES:

- 2 static air cells located in head area
- 12 alternating air cells located in sacrum area
- 4 independent heel relief air cells

OPTIONAL SUPINE POSITION

- Selective deflation of air cells to prevent from cutaneous injuries and facilitate bronchial secretions for mechanically ventilated patients

CPR VALVE

- Allows for deflating the mattress in less than 15 seconds

Axensor AT20

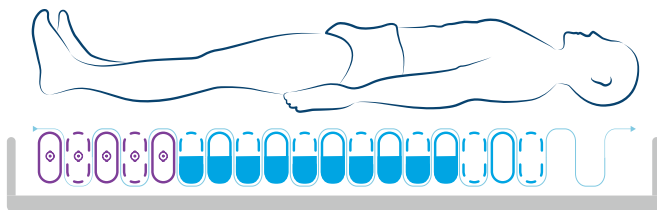

FULL AIR MATTRESS

- 20 cm therapeutic air cells
- Weight limit: 200 kg

4 THERAPEUTIC ZONES

- 2 static air cells located in head area
- 4 cervico-dorsal cells
- 10 air cells around the sacrum area with a static air base to ensure stability and avoid bottoming out
- 5 independent heel relief air cells

LATERAL CPR VALVE

- Allows you to deflate the mattress in less than 15 seconds to proceed with an external cardiac massage

KEY BENEFITS

- Easy to use for caregivers
- Improved quality of treatment and patient's quality of life
- 3 widths available for more comfort
- Technical autodiagnostic by QR code
- Ready to use in a carrying bag
- Environmentally-friendly
- Eco-designed and manufactured in France

PUMP

- Patented system of automatic and continuous calculation of inflation pressure according to patient's morphology and position in bed
- Automatic recognition of the connected pressure care system
- 3 modes: dynamic, static low pressure, care
- Communicating function
- "I" Touch for technical information
- Visual and audible alarms
- Serial number on the pump's back, simplified instruction and QR code on both sides.

	Ref	Pump	Air Height	Foam base	Dimensions	Patient Weight	CPR Valve	Fire Standards
AXENSOR® AT12	VAXT6 /AUTO	22 x 25 x 11.5 cm 3 modes: dynamic, static low pressure and care. (for the axensor cushion only dynamic mode is available in connected mode.) Technology based on alternating pressure 1 cell in 2 over a complete cycle from 14 to 20 minutes Patented system of automatic and continuous calculation of inflation pressure according to patient's morphology and position. Audible and visual alarms . Flow > 8 l/min. 220-240 V - 50Hz Class II type BF; average consumption: 5 Watts Sound power <35 dBA according to NF ISO 3744:1995 Electric and electromagnetic compliance according to standards IEC 60601-1 and 60601-1-2	12 cm	5 cm polyether foam base located in an independent compartment	195 X 87 X 17 cm	30 to 165 kg	4	EN 597 PARTIES 1 & 2 GPEM D1-90 & D1-89 bis
AXENSOR® AT15	VAXT6 /MAX		15,5 cm		195 X 87 X 20,5 cm	30 to 180 kg	4	
AXENSOR® AT15 DV	VAXT6 /MAX-DV		15,5 cm		195 X 87 X 20,5 cm	30 to 180 kg	4	
AXENSOR® AT20	VAXT6/ AT20		20 cm	195 X 87 X 20,5 cm	30 to 200 kg	4		
AXENSOR® CUSHION	VAXT6 /CO /AUTO	10 cm	No foam base on AT20 model and cushion	45 X 45 X 10 cm 17.7 x 17.7 x 3.9 inches	30 to 150 kg			



PRESSURE CARE MATTRESSES



Product code: VAX14

Axtair Automorpho Plus

The Axtair Automorpho Plus mattress helps in preventing pressure ulcers in patients who are at a medium to high risk of pressure ulcer development or bedridden more than 15 hours a day. The mattress helps in treating existing pressure ulcers from stage 1 to 4.

Patient Weight: 30 to 165 kg

- 18 removable and independent Polyurethane Ether cells of 12 cm therapeutic air
 - Head zone: 2 static air cells fitted with a comfort pillow
- 5 cm polyether foam base located in an independent compartment
- 4 independent heel relief air cells
- CPR emergency valve
- Transport plug: system for opening and sharing 2 air channels (autonomy of 8 hours)
- Optional cable protection

2 COVERS AVAILABLE:

- **PROMUST PU HD** (black cover)
- **PROMUST CIC COVER** (blue cover)
Polyamide mesh coated polyurethane/polycarbonate with added silver ions fitted with a non-slip base

Key features

- Effectiveness and therapeutic safety for the patient
- Easy to use for caregivers
- Improved quality of treatment and patient's quality of life
- 3 widths available for more comfort
- Technical autodiagnostic by QR code
- Ready to use in a carrying bag
- Environmentally-friendly
- Eco-designed and manufactured in France

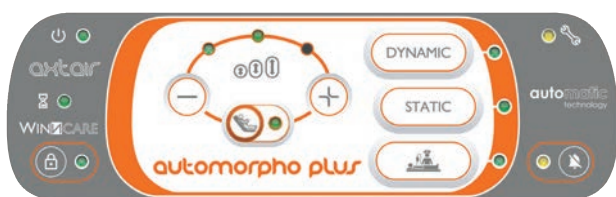

PUMP

- Patented system of automatic and continuous calculation of inflation pressure according to patient's morphology
- 3 modes: dynamic, static low pressure, care
- Comfort settings: customization of comfort and seating position
- Visual and audible alarms.
- Indication for servicing
- Serial number on the pump's back, simplified instruction and QR code on both sides.

Description	Ref	Dimensions/ Weight	Patient Weight	Fire Standards	Key Features
AXTAIR AUTOMORPHO® PLUS (pump + overlay mattress) Promust PU HD cover For 90 cm wide bed	VAXT4/ AUTO-P	195 x 87x17 cm 8 kg	30 to 165 kg	EN 597-1 and 2 GPEM D1 90 Classe D	Overlay mattress CPR emergency valve 18 removable and independent Polyurethane Ether cells of 12 cm therapeutic air 5 cm polyether foam base located in an independent compartment 2 static air cells fitted with a comfort pillow 4 heel reliefs as standard Pump Dimensions: 22 x 25 x 11.5 cm Weight: 2.7 kg Technology based on alternating pressure 1 cell in 2 over a complete cycle from 9 to 14 minutes Patented system of automatic and continuous calculation of inflation pressure Comfort adjustment Visual and audible alarms Flow > 7 l / min Electrical power supply: 220-240 V - 50 Hz Class II type BF Average consumption: 5 Wh Pump decibels: Acoustic pressure according to NF EN3744: <35 dBA Electric and electromagnetic compliance according to the standards IEC 60601-1 Ed.3; IEC 60601-1-2
AXTAIR AUTOMORPHO® PLUS (pump + overlay mattress) Promust CIC cover For 90 cm wide bed	VAXT4/ CIC-P				
AXTAIR AUTOMORPHO® PLUS (pump + overlay mattress) Promust PU HD cover For 100 cm wide bed	VAXT4/ AUTO100-P	195 x 97x17 cm 10 kg			
AXTAIR AUTOMORPHO® PLUS 10 kg (pump + overlay mattress) Promust CIC cover For 100 cm wide bed	VAXT4/ CIC100-P				
AXTAIR AUTOMORPHO® PLUS (pump + overlay mattress) Promust PU HD cover For 120 cm wide bed	VAXT4/ AUTO120-P	195 x 117 x 17 cm 12 kg			
AXTAIR AUTOMORPHO® PLUS (pump + overlay mattress) Promust CIC cover For 120 cm wide bed	VAXT4/ CIC120-P				



PRESSURE CARE MATTRESSES



Product code: VAXT2/ ONE-P

Axtair One[®] Plus

The Axtair One Plus mattress helps in preventing pressure ulcers in patients who are at a medium to high risk of pressure ulcer development or bedridden more than 15 hours a day. The mattress helps in treating existing pressure ulcers from stage 1 to 2.

Patient Weight: 30 to 150kg

KEY BENEFITS

- Easy to use for caregivers
- Improved quality of treatment and patient's quality of life
- 3 widths available for more comfort
- Technical autodiagnostic by QR code
- Ready to use in a carrying bag
- Environmentally-friendly
- Eco-designed and manufactured in France

Key Features

- Therapeutic efficacy for early stages of pressure ulcers
- Easy to use for caregivers
- Technical autodiagnostic by QR code
- Portable and ready to use, with its own carry bag
- Environmentally-friendly
- Eco-designed and manufactured in France



PUMP

- Patented system of automatic and continuous calculation of inflation pressure according to patient's morphology and position in bed
- Automatic recognition of the connected pressure care system
- 3 modes: dynamic, static low pressure, care
- Communicating function
- "I" Touch for technical information
- Visual and audible alarms
- Serial number on the pump's back, simplified instruction and QR code on both sides.

	REF	DIMENSIONS / WEIGHT	PATIENT WEIGHT	Fire Standards	Key Features
AXTAIR ONE® PLUS (pump + overlay mattress) Promust PU cover For 90 cm wide bed	VAXT2/ ONE-P	195 x 87 x 14 cm 8 kg	30 to 150 kg	EN 597-1 and 2 GPEM D1 90 Classe D	Overlay mattress CPR emergency valve 18 removable and independent Polyurethane Ether cells of 12 cm therapeutic air (300µ) 5 cm polyether foam base Pump Dimensions: 22 x 25 x 11.5 cm Weight: 2.7 kg Technology based on alternating pressure 1 cell in 2 over a complete cycle from 9 to 14 minutes Patented system of automatic and continuous calculation of inflation pressure Comfort adjustment Visual and audible alarms. Flow > 7 l / min Electrical power supply: 220-240 V - 50 Hz Class II type BF Average consumption: 5 Wh PUMP decibels: Acoustic pressure according to NF EN3744: <35 dBA Electric and electromagnetic compliance according to the standards IEC 60601-1 Ed.3; IEC 60601-1-2
AXTAIR ONE® PLUS (pump + overlay mattress) Promust CIC cover For 90 cm wide bed	VAXT2/ ONE/ CIC-P				



Ekamove

The Ekamove is the latest generation in patient repositioning solutions, innovatively designed to deliver person specific pressure care.

SAFE TO USE

- The air chambers provide a soft lift beneath the mattress which forms gently to the shape of the patient's body. This delivers less pressure and comparatively less shearing force than a plate system.
- A memory card is included to track patient repositioning, providing diagnostic and operational information to clinicians and service managers.
- Works effectively with standard, foam mattresses so can negate the need for more expensive hybrid or dynamic models.

ULTIMATE FLEXIBILITY

- The Control Unit is simple to operate with 4 easy to use programmes.
- An additional specialist programme can be used when

tailored care is required for more complex cases.

- The air chamber inflates to turn the patient to any angle between 0° and 30°, with a choice of dwell time settings between 10 minute minimum dwell time.
- The Ekamove can be used with any hospital mattress and should be integrated into a healthcare bed with side protection
- The adjustable clamp on the control unit means it can fit tightly onto any type of bed end.
- Suitable for patients that weigh between 15 kg to 300 kg, with a wider bariatric version also available.
- For some patients, the Ekamove with leg extension maybe the more suitable model if a full length system is required.

TECHNICAL SPECIFICATIONS

Weight

Base unit: 2.8 kg

Air chambers incl. hoses: 1.5 kg

Dimensions

(LxWxH) Base Unit: 21 cm x 12cm x 31 cm

Dimensions (LxWxH) Air Chambers incl. hoses: 110 cm x 80 cm

Electrical Data

Operating voltage: 240V

Frequency: 50Hz/60Hz

Output: Max. 18W

Classification: Protection class II

Fuse (in the apparatus): M3A, 230V micro-fuse

Patient Positioning

Positioning Angle: 0° to 35° (depending on body shape)

Positioning times: 10 to 120 minutes per partial positioning stage ±15 seconds

Contact and moisture protection

Housing and sensors: IP 33

Storage Conditions

Temperature range: -10° to 50° C

Relative Humidity: 0% to 95% no condensation

Operating conditions

Internal power supply for the warning system in case of power failure: 2 no-maintenance batteries type AA 1.2V 1900mA



Product code: MPCA191214

Key Features

1. Can be packed down into a small **carrying bag** for transportation and storage
2. **Air chambers** are placed **under the mattress** and inflate slowly and gently under the patient
3. The **control unit** is hooked over the **foot of the bed** using an adjustable bracket
4. A **washable PU cover** protects the air chambers
5. **Air tubes** are clearly marked left and right for easy fitting
6. An **SD card** is inserted under the **control unit** for tracking patient movement
7. Control unit includes **quick release CPR function**

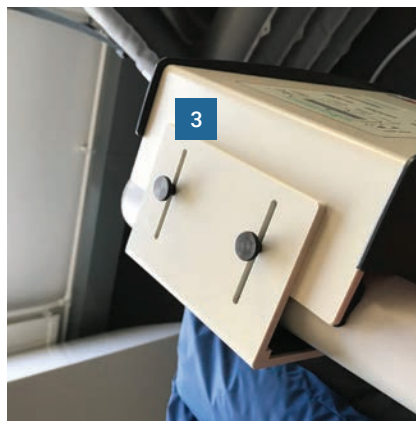



Carmen	Furniture board colours		Surround, edging and hand rail colours	Material
	Standard colours	Other colours as a option		
Abelia II boards	Inside finish Light Beech, surround and handrail RAL 1001	Choice of melamine finishes from our colour chart, 19 mm thick	Painted steel hand rail: RAL 1001 and polyethylene ends RAL 1001 Edging: RAL 1001 glued ABS	Painted steel hand rail Chipboard boards 19 mm Melamine-faced ABS edging
Carmen II boards Carmen II boards Spaces for wooden side rails	Light Beech inside finish, matching edging and footboard: smooth epoxy hand rail and polyethylene ends in RAL 8011 brown	Choice of melamine finishes from our colour chart, 30 mm thick	Footboard: Painted steel hand rail: RAL 1001 and Polyethylene ends Ral1001 Glued ABS edging, RAL 1001 colour	Painted steel hand rail 30 mm melamine-faced chipboard boards ABS edging
Furniture	Light Beech inside finish, RAL 1001 surround	Choice of melamine finishes from our colour chart, 19 mm thick	RAL 1001 standard colour edging	Chipboard unit with 19 mm Melamine-face / 1 mm ABS edging Chipboard boards with 19 mm Melamine-face / 1 mm ABS edging

Carmen Room

FURNITURE FOR THE CARMEN ROOM



CHAIR

Dimensions

W470 x D530 x H815 mm

SITTING:

W470 x D460 x H460 mm

- Choice of PVC coating



TABLE

Dimensions

W875 x D548 x H758 mm



DRESSER

Dimensions

W875 x D548 x H758 mm

- 3 drawers with soft shutting feature



CHAIR

Dimensions

W560 x D560 x H815 mm

SITTING: W440 x D460 x H460 mm

- Choice of PVC coating
- Arm rest height: 68 cm



DESK

Dimensions

W1075 x D548 x H758 mm

- 1 right-hand drawer
- Rear access for the bridge chair



TABLE WITH DRESSER

Dimensions

W1416 x D548 x H758 mm

- One leg for open access, bridge chair access 600 mm wide and 720 mm high
- 3 right-hand drawers



SINGLE DOOR WARDROBE

Dimensions

W675 x D548 x H1793 mm

- Left-hand hinge
- 1 shelf
- 1 clothes rail



TWO DOOR WARDROBE

Dimensions

W1125 x D548 x H1793 mm

- 1 full-width top shelf
- 3 half-shelves
- 1 right-hand clothes rail



BEDSIDE CABINET

Dimensions

W445 x D447 x H681 mm

W538 x D560 x H814 mm with 30 L refrigerator

- 2 rear mobility castors
- 1 drawer with removable tray
- 1 shelf with bottle space
- Hinge door hung to the left as standard, can be hung to the right as an option



Auzence	Furniture board colours		Surround, edging and hand rail colours	Material
	Standard colours	Other colours as a option		
Boards	Grey Dragon Tree interior finish RAL 7030 lacquer edging	Choice of melamine finishes from our colour chart.	Taupe epoxy hand rail and surround RAL 7030 lacquer	Uprights (curves) in solid wood and inside finish in melamine-faced MDF. Painted steel hand rail
Furniture	RAL 7030 epoxy hand rail RAL 7030 lacquer upright			Painted steel tube uprights with inside finish in melamine faced MDF (unit doors and tops in melamine-faced 19 mm chipboard), choice of varnished or lacquered edging

Auzence Room

FURNITURE FOR THE CARMEN ROOM

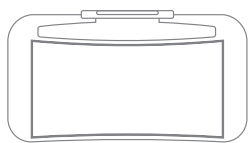

BOARDS

Dimensions (head/foot board)

W958 x H958 mm

- Curved uprights in solid wood
- Hand rails in epoxy steel tube, inside



BEDSIDE CABINET

Dimensions

W1072 x D586 x H 775mm

- 1 right-hand drawer, rear access for bridge chair



DESK

Dimensions

W1072 x D586 x H 775mm

- 1 right-hand drawer, rear access for bridge chair



BEDROOM TABLE

Dimensions

W872 x D586 x H775 mm



DRESSER

Dimensions

W872 x D586 x H775 mm

- 3 drawers



TABLE WITH DRESSER

Dimensions

W872 x D586 x H775 mm

- 3 right-hand drawers



SINGLE DOOR WARDROBE

Dimensions

W672 x D596 x H1815 mm

- Left-hand hinge
- 1 shelf
- 1 clothes rail

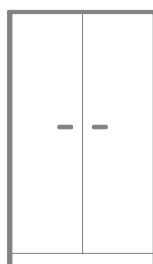

TWO DOOR WARDROBE

Dimensions

W1122 x D596 x H1815 mm

- 1 full-width top shelf
- 3 half-shelves
- 1 right-hand clothes rail



Dagone	Furniture board colours		Surround, edging and hand rail colours	Material
	Standard colours	Other colours as a option		
Boards	Inside finish in Light Beech. RAL 1001 Lacquered hand rails and edging	Choice of melamine finishes from our colour chart. Veneered edging	Edging and surround in RAL 1001 as standard.	MDF hand rail and melamine faced MDF inside
Furniture				Unit in melamine-faced 19 mm chipboard / 1 mm ABS edging Tops in MDF with 19 mm melamine-face / Lacquered edging

Dagone Room

FURNITURE FOR THE DAGONE ROOM



BOARDS

Dimensions

Head: W1005 x H561mm

Foot: W1005 x H641mm

- Curved hand rail
- Inside boards are in melamine faced MDF



DESK

Dimensions

W1085 x D548 x H758 mm

- 1 right-hand drawer, rear access for bridge chair



BEDROOM TABLE

Dimensions

W885 x D548 x H758 mm

- Not compatible with Bridge for bridge chair



DRESSER

Dimensions

W885 x D548 x H758 mm

- 3 drawers

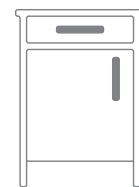

TABLE WITH DRESSER

Dimensions

W1426 x D548 x H758mm

- 3 right-hand drawers



BEDSIDE CABINET

Dimensions

W872 x D586 x H775 mm

- 2 rear mobility castors
- 2 adjustable feet at the front
- 1 drawer with removable tray
- Hinge door hung to the left
- 1 shelf with bottle space



SINGLE DOOR WARDROBE

Dimensions

W685 x D548 x H1793 mm

- Left-hand hinge
- 1 shelf
- 1 clothes rail

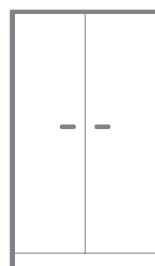

TWO DOOR WARDROBE

Dimensions

W1135 x D548 x H1793 mm

- 1 full-width top shelf
- 3 half-shelves
- 1 right-hand clothes rail



Val de Vie	Panelling and Furniture board colours		Border, edging and handrail colour chart	Material
	Standard colours	Other colours as a option		
Panelling	Interior in Light beech or Platane d'Automne.	Melamine-covered décor of choice from our colour shades.	Uprights and handrail in dark beech.	Uprights and handrail in solid wood and internal décor in 19mm melamine-covered chipboard.
Furniture				Box in 19 mm melamine-covered chipboard. MDF borders and doors and trays with MDF melamine-covered interior décor. Your choice of varnished or lacquered edges.

Val de Vie Room



FURNITURE FOR THE VAL DE VIE ROOM



PANELLING

Dimensions

Head: 1032 x 590 mm

Foot: 960 x 590mm

- With or without wooden rail possibility.
- Solid wood borders. Internal panelling in melamine.



DESK

Dimensions

876 x 530 x 760 mm

- 1 recess, 1 right drawer.
Not compatible with bridge.



BEDROOM TABLE

Dimensions

878 x 515 x 760mm

- No recess or drawer.



TABLE WITH DRAWERS

Dimensions

1470 x 530 x 760 mm

- 3 drawers on the right



CHIFFONNIER

Dimensions

710 x 530 x 1030 mm

- 3 right-hand drawers



BEDSIDE TABLE

Dimensions

448 x 410 x 700

550 x 590 x 840 with Fridge

- 4 fixed legs
- 1 drawer equipped with a removable tray
- 1 door hinge on the left
- 1 shelf with a hollow for a bottle.
- Dimensions of the version with refrigerator
- L 540xI 550xH 890 mm (model with hinges on right)



SINGLE DOOR WARDROBE

Dimensions

676 x 510 x 1825 mm

- Hinges on the left
- 1 shelf, 1 clothes rack.

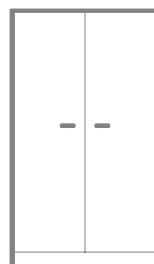

TWO DOOR WARDROBE

Dimensions

1126 x 510 x 1825 mm

- 1 high shelf the width of the wardrobe. Separation between 3 half-shelves and clothes rack on the right.



Côte de Lumiere	Panelling and Furniture board colours		Border, edging and handrail colour chart	Material
	Standard colours	Other colours as a option		
Panelling	Interior in Light beech or Platane d'Automne.	Melamine-covered décor of choice from our colour shades.	Uprights and handrail in Dark beech.	Uprights and handrail in solid wood and internal décor in 19mm melamine-covered chipboard.
Furniture				Box in 19 mm melamine-covered chipboard. MDF borders and doors and trays with MDF melamine-covered interior décor. Your choice of varnished or lacquered edges.

Côte de Lumiere Room

FURNITURE FOR THE CÔTE DE LUMIERE ROOM



FURNITURE

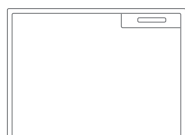

DESK

Dimensions

876 x 530 x 807 mm

- 1 recess, 1 right drawer.
Not compatible with bridge.

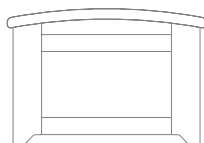

PANELLING

Dimensions

1058 x 680 mm

- With or without wooden rail possibility.
- Solid wood borders. Arched handrail.
- Internal panelling in melamine.



BEDROOM TABLE

Dimensions

878 x 515 x 807 mm

- Without recess



CHEST OF DRAWERS

Dimensions

876 x 530 x 807 mm

- 3 drawers



TABLE WITH DRAWERS

Dimensions

1470 x 530 x 820 mm

- 3 drawers on the right



BEDSIDE TABLE

Dimensions

448 x 410 x 739 mm

540 x 550 x 890 mm with Fridge

- 4 fixed legs, 2 of which are arched.
1 drawer equipped with a removable tray.
- 1 door hinge on the left.
- 1 shelf with a hollow for a bottle.
- Dimensions of the version with refrigerator: L540xW.1.550xH.890 mm
(model with hinges on right)



SINGLE DOOR WARDROBE

Dimensions

676 x 510 x 1825 mm

- Hinges on the left,
- 1 shelf, 1 clothes rack.

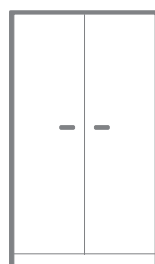

TWO DOOR WARDROBE

Dimensions

1126 x 510 x 1825 mm

- 1 high shelf the width of the wardrobe.
Separation between 3 half- shelves and clothes rack on the right.

TALK TO OUR CUSTOMER SERVICE TEAM

Designing care home bedrooms

Ask one of Area Sales Managers to call and show you the range of care home bedroom furniture available. Using an online configurator, you can select bed and head and footboards colours, as well as complimentary furniture to make your environment a home from home experience.

Ceiling hoists

Our ceiling hoist specialists will visit your premises to measure the space and design the tracking and lifting pod system. Totally bespoke and fitted by a qualified engineer, the Scandinavian styling will bring a modern feel to your care setting.

Selecting beds, mattresses and mobile safe patient lifting devices

Talk to one of our Area Sales Managers about the products that are the best fit for your business. All our products come with a standard warranty and we also offer extended servicing and warranty packages.

Ask our customer service team

If you have any questions about us, our products or our services, or would like to organise a free demonstration or arrange a visit from one of our team, please get in touch.



WHAT CAN WE DO FOR YOU?

Do you have questions about one or more products in this brochure or would you like to know more about Winncare solutions for patient lifting, hygiene, beds, mattresses and cushions, please feel free to contact us at any time.

CONTACT US TODAY

For more information visit

winncare.uk

Email: enquiries@winncare.uk

Phone: 0800 2800 485

We look forward to hearing from you!



Luna Ceiling Hoist / Lifting Cushions / Hygiene / Stand Aids / Bedroom Furniture

enquiries@winncare.uk

winncare.uk

